

## The genes of the coactivator TIF2 and the corepressor SMRT are primary $1\alpha,25(\text{OH})_2\text{D}_3$ targets<sup>☆</sup>

Thomas W. Dunlop\*, Sami Väisänen, Christian Frank, Carsten Carlberg

Department of Biochemistry, University of Kuopio, P.O. box 1627, FIN-70211 Kuopio, Finland

### Abstract

The complex of the receptor for the hormone  $1\alpha,25$ -dihydroxyvitamin  $\text{D}_3$  ( $1\alpha,25(\text{OH})_2\text{D}_3$ ), Vitamin  $\text{D}_3$  receptor (VDR), the retinoid X receptor (RXR) and a  $1\alpha,25(\text{OH})_2\text{D}_3$  response element (VDRE) is considered to be the molecular switch for nuclear  $1\alpha,25(\text{OH})_2\text{D}_3$  signaling. In the presence of ligand the VDR–RXR complex interacts with coactivator (CoA) proteins that in turn contact components of the basal transcriptional machinery resulting in an enhanced transcription of  $1\alpha,25(\text{OH})_2\text{D}_3$  target genes. In the absence of ligand the VDR remains bound to the DNA and interacts with corepressor (CoR) proteins that are involved in gene silencing activity. We treated MCF-7 breast cancer cells with  $1\alpha,25(\text{OH})_2\text{D}_3$  for increasing amounts of time, extracted mRNA and screened by real-time PCR the members of the p160 CoA and NCoR CoR families. We find that of the p160 coactivators, only TIF2 was responsive to  $1\alpha,25(\text{OH})_2\text{D}_3$ . Similarly SMRT but not NCoR1 gene transcription was sensitive to  $1\alpha,25(\text{OH})_2\text{D}_3$  treatment. *In silico* analysis revealed that both TIF2 and SMRT promoters have substantial numbers of VDREs compared to the promoters of the other family members. These VDREs are formed by direct repeats of the core binding motif RGKTCA with a three nucleotide spacing (DR3). We suggest that some or all of these DR3-type VDREs are responsible for the observed responsiveness of TIF2 and SMRT to  $1\alpha,25(\text{OH})_2\text{D}_3$ .

© 2004 Elsevier Ltd. All rights reserved.

**Keywords:** Gene regulation; Vitamin D; Coactivators; Corepressors; Vitamin D response elements

### 1. Introduction

An essential prerequisite for a direct modulation of transcription via  $1\alpha,25$ -dihydroxyvitamin  $\text{D}_3$  ( $1\alpha,25(\text{OH})_2\text{D}_3$ )-triggered protein–protein interactions is the location of an activate Vitamin  $\text{D}_3$  receptor (VDR) close to the basal transcriptional machinery. This is achieved through the specific binding of the VDR to a VDRE in the regulatory region of a primary  $1\alpha,25(\text{OH})_2\text{D}_3$  responding gene [1]. The DNA binding domain (DBD) of the VDR contacts the major groove of a hexameric sequence, referred to as a core binding motif, which has the consensus sequence RGKTCA (R

= A or G, K = G or T). The affinity of monomeric VDR to a single binding motif is insufficient for the formation of a stable protein–DNA complex and thus VDR requires formation of homo- and/or heterodimeric complexes with a partner nuclear receptor (NR) in order to allow efficient DNA binding [2]. In most cases the heterodimeric partner of VDR is retinoid X receptor (RXR) and simple VDREs are often formed by a direct repeat of two hexameric core binding motifs spaced by three nucleotides (DR3) [3].

Corepressor (CoR) proteins, such as nuclear corepressor 1 (NCoR1) and silencing mediator of retinoid and thyroid hormone receptors (SMRT) [4], link non-liganded, DNA-bound VDR–RXR heterodimers to enzymes with histone deacetylase activity that cause chromatin condensation [5]. This gives VDR intrinsic repression properties comparable to retinoic acid and thyroid hormone receptors. The conformational change within VDR's ligand binding domain (LBD) after binding of  $1\alpha,25(\text{OH})_2\text{D}_3$  or one of its agonistic analogues results in replacing a CoR with a coactivator (CoA) protein of the p160-family, such as steroid receptor coactivator 1 (SRC-1), transcriptional intermediary factor 2 (TIF2) and receptor associated coactivator 3 (RAC3) [6]. These CoAs link the ligand-activated VDR to enzymes displaying histone acetyl transferase activity

**Abbreviations:**  $1\alpha,25(\text{OH})_2\text{D}_3$ ,  $1\alpha,25$ -dihydroxyvitamin  $\text{D}_3$ ; CoA, coactivator; CoR, corepressor; DR3, direct repeat spaced by 3 nucleotides; NCoR1, nuclear corepressor 1; NR, nuclear receptor; RAC3, receptor associated coactivator 3; RE, response element; RXR, retinoid X receptor; SMRT, silencing mediator of retinoid and thyroid hormone receptors; SRC-1, steroid receptor coactivator 1; TIF2, transcriptional intermediary factor 2; TSS, transcription start site; VDR, vitamin  $\text{D}_3$  receptor; VDRE,  $1\alpha,25(\text{OH})_2\text{D}_3$  response element; DBD, DNA binding domain; LBD, ligand binding domain

<sup>☆</sup> Presented at the 12th Workshop on Vitamin D (Maastricht, The Netherlands, 6–10 July 2003).

\* Corresponding author. Tel.: +358-17-163393; fax: +358-17-2811510.

E-mail address: [dunlop@uku.fi](mailto:dunlop@uku.fi) (T.W. Dunlop).

that cause chromatin opening. Ligand-activated VDR–RXR heterodimers then exchange CoAs of the p160-family for those of the DRIP/TRAP family. The latter are part of a mediator complex of approximately 15 proteins that build a bridge to the basal transcription machinery [7]. In this way ligand-activated VDR–RXR heterodimers fulfill two tasks, opening chromatin and activating transcription.

Most well studied gene promoters indicate that multiple response elements are required for transcriptional activation. Many of the known  $1\alpha,25(\text{OH})_2\text{D}_3$  target genes contain more than one functional VDRE. Therefore larger promoter regions need to be investigated in order to identify all potentially functional VDREs. Individual hormone response systems are known to influence each other. This can take the form of repressive or positive effects occurring at the level of protein–protein interactions [8] or direct transcriptional effects [9] and may involve

mRNA was extracted using Tri-reagent (Sigma–Aldrich, St. Louis, USA) and Oligotex mini mRNA kit (Qiagen, Hilden, Germany) respectively. One hundred nanograms of mRNA was used as a template in cDNA synthesis reaction using 100 pmol of oligodT<sub>18</sub> primer in the presence of reverse transcriptase enzyme (Fermentas, Vilnius, Lithuania). The reaction was performed at 37 °C for 1 h. Real-time quantitative PCR was performed in an IQ-cycler (BioRad, Hercules, USA) using the dye SybrGreen (Molecular Probes, Leiden, The Netherlands). In PCR reactions, 3 mM MgCl<sub>2</sub> was used for all primers except for SMRT where 1.5 mM was used. The PCR cycling conditions used were: 40 cycles 95 °C for 30 s, 58 °C for 30 s and 72 °C for 40 s. Fold inductions were calculated using the formula  $2^{-(\Delta\Delta\text{Ct})}$ , where  $\Delta\Delta\text{Ct}$  is the  $\Delta\text{Ct}_{(1\alpha,25(\text{OH})_2\text{D}_3)} - \Delta\text{Ct}_{(\text{EtOH})}$ ,  $\Delta\text{Ct}$  is  $\text{Ct}_{(\text{test gene})} - \text{Ct}_{(\text{control gene})}$  and Ct is the cycle at which the threshold is crossed. The primers used were as follows:

Gene	Primer	Sequence	Product size
ARPO	Forward	5'-AGATGCAGCAGATCCGCAT-3'	318
	Reverse	5'-GTGGTGATACCTAAAGCCTG-3'	
SRC-1	Forward	5'-TGTTTCAGTCAAGCTGTCCAG-3'	440
	Reverse	5'-ATTCAGTCAGTAGCTGCTGA-3'	
TIF2	Forward	5'-AATGGCACATACACAGAGTC-3'	253
	Reverse	5'-TCATGCTGATCTGTCCCTGTC-3'	
RAC3	Forward	5'-CTTTGGTTCGAGTGTCTAGTC-3'	250
	Reverse	5'-TCATGTTTCATCTGTCCCATG-3'	
NCoR1	Forward	5'-GTGGTGAGACACGAAGAGAG-3'	280
	Reverse	5'-TGGAGTACTGCTGAGCATC-3'	
SMRT	Forward	5'-AACATGCCAGCACCAACATG-3'	536
	Reverse	5'-GTGTCTCGTACTGCGAGCAG-3'	

the direct activation of coregulator genes. Therefore, we monitored the effects of  $1\alpha,25(\text{OH})_2\text{D}_3$  on the p160 CoA and NCoR1/SMRT CoR gene expression by real-time PCR over the first 6 h of hormone exposure. We find that the TIF2 and SMRT genes are direct transcriptional targets of  $1\alpha,25(\text{OH})_2\text{D}_3$  and that this is probably due to a higher number of DR3-type VDREs found in the promoters of these genes.

## 2. Materials and methods

### 2.1. Cell treatments, RNA extraction, cDNA synthesis and real-time PCR

MCF-7 breast cancers cells were grown in DMEM media supplemented with charcoal treated 5% foetal calf serum to a density of 50–60% confluency and treated with either 100 nM  $1\alpha,25(\text{OH})_2\text{D}_3$  or vehicle (EtOH). Total RNA and

### 2.2. In silico screening of coregulator promoters

25,000 bp upstream from the transcription start site (TSS) of these genes was retrieved from the University of California Human Genome Browser Gateway (<http://www.genome.ucsc.edu/cgi-bin/hgGateway>). Sequences were entered into MacMolly® (SoftGene, Berlin, Germany) Analyze files and the distribution of consensual hexamers (RGKTCA) including those with one nucleotide change from this sequence are described. The sequences were then analyzed for potential DR3-type VDREs.

## 3. Results

The levels of CoA and CoR expression in MCF-7 cells were assessed by real-time PCR. In general the coregulators mRNA levels tested fall between an abundance of 0.01–0.0001 relative to the reference gene acidic ribopro-

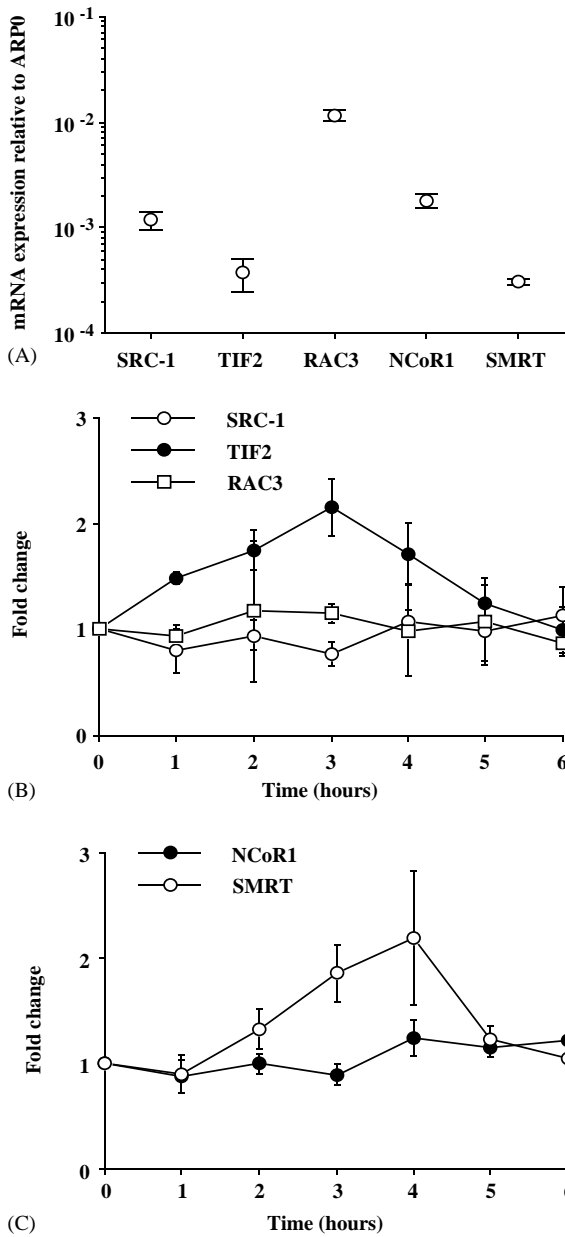

Fig. 1. Effects of  $1\alpha,25(\text{OH})_2\text{D}_3$  on coregulator mRNA levels in MCF-7 breast cancer cells. Real-time PCR was used to determine the levels of coregulator mRNA relative to the control gene acidic riboprotein P0 (A) and the effects of  $1\alpha,25(\text{OH})_2\text{D}_3$  treatment on (B) p160 coactivator and (C) NCoR1/SMRT CoR family gene expression. The results were the means of at least three independent experiments. Bars indicate standard deviations.

tein P0, ARP0, also known as 36B4 (Fig. 1A). Of the coregulators tested, RAC3 is the most prevalent with a relative abundance of approximately 0.01. SRC-1 and TIF2 have abundances relative to ARP0 of  $(1.20 \pm 0.24) \times 10^{-3}$  and  $(3.77 \pm 1.34) \times 10^{-4}$ , respectively. The CoRs, NCoR1 and SMRT have levels of  $(1.82 \pm 0.26) \times 10^{-3}$  and  $(3.08 \pm 0.21) \times 10^{-4}$  relative to ARP0 mRNA, respectively.

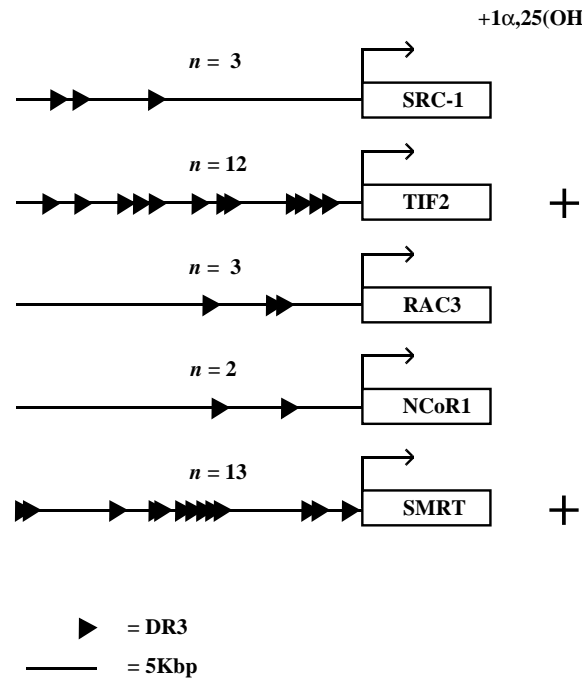

Fig. 2. Number of putative DR3-type VDREs elements in coregulator promoters correlates with  $1\alpha,25(\text{OH})_2\text{D}_3$  activation. 25,000 bp immediately upstream of the respective genes TSS were screened for the sequence RGKTCA. DR3-type VDREs were chosen on the basis of having two hexamers that contain no more than one discrepancy from the consensus sequence.

To investigate the effects of  $1\alpha,25(\text{OH})_2\text{D}_3$  on these genes, we measured the individual mRNA levels using real-time PCR from a series of cDNAs derived from MCF-7 cells that had been treated with sequentially longer times with 100 nM  $1\alpha,25(\text{OH})_2\text{D}_3$ . Fig. 1B and C shows the results of these experiments. Only TIF2 and SMRT are upregulated by  $1\alpha,25(\text{OH})_2\text{D}_3$  and reach a maximum of two-fold at 3 h.

The above results lead us to investigate the likelihood of functional VDREs in the promoters of TIF2 and SMRT. *In silico* analysis of the 25 kbp upstream of the TSS of the five coregulator genes for the existence of DR3-type VDREs identified a number of candidates, which are schematically depicted in Fig. 2. We found that there were larger numbers of DR3-type VDREs in the promoters of both TIF2 and SMRT (12 and 13, respectively) compared to SRC-1, RAC3 and NCoR1 (3, 3 and 2, respectively).

#### 4. Discussion

We have found that the genes of single members of two important coregulator families (p160 CoAs and NCoR1/SMRT CoRs) are transcriptionally responsive to  $1\alpha,25(\text{OH})_2\text{D}_3$ . Since these responses are nascent within 2 h of the exposure of these cells it reasonable to con-

clude that these genes are primary responding genes. The widely accepted condition of immediate transcriptional response to  $1\alpha,25(\text{OH})_2\text{D}_3$  exposure is the existence of VDREs in the promoter regions of these genes. *In silico* analysis revealed that the numbers of putative DR3-type VDREs correlated with the hormones ability to stimulate gene expression. In the case of TIF2 and SMRT, 12 and 13 DR3-type VDREs were found in the first 25,000 bp distal to the TSS. In addition, multiple DR3-type VDREs were found within the first 5000 bp. A study of the whole human CYP24 gene promoter by chromatin immunoprecipitation assay demonstrated that  $1\alpha,25(\text{OH})_2\text{D}_3$  activated multiple positions within this promoter and not only the obvious DR3 cluster in the proximal region of the promoter (Väisänen et al., submitted for publication). The question, whether multiple DR3-type VDREs at different positions in both TIF2 and SMRT promoters are responsible for the activation of these genes is presently under investigation.

An important aspect of these results is the apparent specificity where only one member gene of each coregulator family is activated by  $1\alpha,25(\text{OH})_2\text{D}_3$ . This may point to  $1\alpha,25(\text{OH})_2\text{D}_3$  having a role in changing the transcriptional competence of cells. A result of selected manipulation of coregulators could be phenomems of trans-repression (in the case of increased amounts of CoR) [10] and priming to other signals which the cell may receive (in the presence of more CoA). The specificity of gene upregulation and possible protein abundance could favour and disadvantage other transcription factor systems and ultimately alter physiological processes occurring within the cell. For example, it was found that the ratios of SRC-1 and TIF2 effect energy metabolism in murine fat tissues [11]. Therefore our results suggest that  $1\alpha,25(\text{OH})_2\text{D}_3$  upregulates coregulators in a gene specific manner and this may alter the cells transcriptional capabilities.

## Acknowledgements

We would like to thank Maija Hiltunen for technical assistance in cell culture. Both the Academy of Finland (grant 50319) and TEKES supported this research.

## References

- [1] C. Carlberg, P. Polly, Gene regulation by vitamin  $\text{D}_3$ , Crit. Rev. Eukaryot. Gene Exp. 8 (1998) 19–42.
- [2] C. Carlberg, I. Bendik, A. Wyss, E. Meier, L.J. Sturzenbecker, J.F. Grippo, W. Hunziker, Two nuclear signalling pathways for vitamin D, Nature 361 (1993) 657–660.
- [3] A. Toell, P. Polly, C. Carlberg, All natural DR3-type vitamin D response elements show a similar functionality in vitro, Biochem. J. 352 (2000) 301–309.
- [4] L.J. Burke, A. Baniahmad, Co-repressors 2000, FASEB J. 14 (2000) 1876–1888.
- [5] P. Polly, M. Herdick, U. Moehren, A. Baniahmad, T. Heinzel, C. Carlberg, VDR-Alien: a novel, DNA-selective vitamin  $\text{D}_3$  receptor-corepressor partnership, FASEB J. 14 (2000) 1455–1463.
- [6] C. Leo, J.D. Chen, The SRC family of nuclear receptor coactivators, Gene 245 (2000) 1–11.
- [7] C. Rachez, B.D. Lemon, Z. Suldan, V. Bromleigh, M. Gamble, A.M. Näär, H. Erdjument-Bromage, P. Tempst, L.P. Freedman, Ligand-dependent transcription activation by nuclear receptors requires the DRIP complex, Nature 398 (1999) 824–828.
- [8] G. Min, H. Kim, Y. Bae, L. Petz, J.K. Kemper, Inhibitory cross-talk between estrogen receptor (ER) and constitutively activated androstane receptor (CAR). CAR inhibits ER-mediated signaling pathway by squelching p160 coactivators, J. Biol. Chem. 277 (2002) 34626–34633.
- [9] S.P. Tenbaum, S. Juenemann, T. Schlitt, J. Bernal, R. Renkawitz, A. Munoz, A. Baniahmad, Alien/CSN2 gene expression is regulated by thyroid hormone in rat brain, Dev. Biol. 254 (2003) 149–160.
- [10] M. Macias Gonzalez, C. Carlberg, Cross-repression, a functional consequence of the physical interaction of non-liganded nuclear receptors and POU domain transcription factors, J. Biol. Chem. 277 (2002) 18501–18509.
- [11] F. Picard, M. Gehin, J. Annicotte, S. Rocchi, M.F. Champy, B.W. O'Malley, P. Chambon, J. Auwerx, SRC-1 and TIF2 control energy balance between white and brown adipose tissues, Cell 111 (2002) 931–941.